

FRIULAIR[®]



LIQUID CHILLERS CATALOG

Discover cooling solutions designed to enhance your productivity



MADE IN
ITALY



AIR AND WATER TOGETHER TO MEET ALL YOUR COOLING REQUIREMENTS

Since 1989, Friulair has been driving innovation in compressed air treatment and industrial process cooling. In 2009, we expanded our expertise by creating the Friulair Chillers division, entirely dedicated to industrial refrigeration.

With decades of experience, a multidisciplinary team, and rigorous quality controls, we deliver reliable, versatile, efficient, and sustainable products. We design and build every unit with engineering passion and Italian know-how, always keeping our customers at the center. We develop tailor-made solutions for every industrial requirement and support our partners with dedicated selection software, technical service, and full pre- and after-sales assistance.

**Innovation, Transparency, Sustainability, And
Quality Guide Every Decision We Take.**

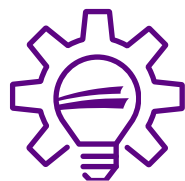

**INDUSTRY 4.0
READY**



**SEPR HT
READY**



**ISO 9001
ISO 14001**



**ETHICAL CODE
MODEL 231**

INTRODUCTION

WHAT IS AN INDUSTRIAL CHILLER AND WHY IS IT ESSENTIAL IN PRODUCTION?

Industrial chillers are units designed to remove the heat generated by machinery, processes, or industrial environments, ensuring consistency, efficiency, and operational safety.

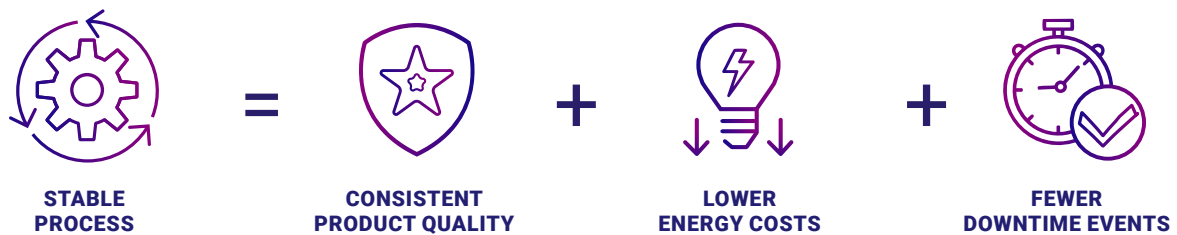

Differences Between HVAC Chillers And Process Chillers:

- **HVAC chillers** are intended for thermal comfort in residential or commercial environments (offices, hotels, shopping centers).
- **Process chillers** are designed for industrial applications where precision, reliability, and continuous operation are essential.

PARAMETERS	HVAC CHILLERS	PROCESS CHILLERS
PURPOSE	Thermal comfort	Precise and continuous cooling
DUTY CYCLE	Intermittent	Continuous, 24/7/365
TOLERANCES	Wide	Narrow (e.g. ± 1 °C)
LOAD	Variable, large fluctuations	Stable or rapidly fluctuating
CRITICALITY	No issue if the environment varies by a few degrees	Even minor deviations can stop a production line
RELIABILITY REQUIRED	Moderate	Maximum
ELECTRONIC CONTROLS	Basic	Advanced

What Should You Know When Choosing The Right Chiller?

- Desired supply and return water temperature
- Water flow rate
- Type of fluid to be cooled (water, glycol mixture, oil, etc.)
- Environmental conditions (indoor/outdoor, climate, seasonality)
- Application type (continuous or intermittent, with peaks, etc.)
- Requirements for precision, noise level, efficiency

Friulair's Tools To Support Selection:



TECHNICAL SELECTION SOFTWARE:

to simulate and calculate cooling capacity under real conditions



COMMERCIAL AND TECHNICAL SUPPORT:

available both before and after sales



DETAILED DATASHEETS

and performance data





Efficiency and Sustainability

- Many of our models are designed to ensure:
- High energy efficiency, even under partial load conditions
- Low environmental impact, thanks to the use of low-GWP refrigerants
- Full compliance with European directives and our customers' sustainability goals

Easy Maintenance

All our models are designed so that every component, especially those subject to maintenance or cleaning, can be accessed easily and safely by the operator.

**FRIULAIR IS THE RIGHT CHOICE FOR THOSE SEEKING
RELIABLE PERFORMANCE, ENERGY SAVINGS,
AND A SOLID TECHNICAL PARTNER.**



**HIGH ENERGY
EFFICIENCY**



**LOW ENVIRONMENTAL
IMPACT**



**FRIENDLY
MAINTENANCE**



**TECHNICAL
PARTNER**

APPLICATION SECTORS OF FRIULAIR CHILLERS



BREWERIES



Friulair chillers guarantee precise temperature control during fermentation and maturation, helping brewers achieve consistent taste, reduce batch variations, and optimize production times, ensuring a higher yield and satisfied customers.



WINERIES



Efficient cooling solutions that protect wine quality throughout fermentation and storage. By maintaining thermal stability, Friulair chillers preserve flavor and aroma, enabling winemakers to consistently deliver premium wines to the market.



FOOD & BEVERAGES



Reliable thermal management for pasteurization, rapid cooling, and storage. Friulair chillers improve food safety, extend shelf life, and enhance productivity, giving producers the confidence to meet strict standards while reducing operating costs.



LABORATORIES & PHARMACEUTICAL



Stable thermal conditions with high precision and reliability. Our chillers ensure consistent test results, safeguard sensitive samples, and support continuous medicine production, helping laboratories and pharma companies maintain compliance and accelerate innovation.



AIR CONDITIONING & DATA CENTERS



Efficient cooling for commercial spaces and critical IT environments. Friulair chillers maximize comfort, protect sensitive equipment, and reduce downtime risks, ensuring reliable performance in mission-critical operations.



OIL & GAS



Rugged cooling solutions designed for harsh industrial conditions. Friulair chillers maintain safe operating temperatures, reduce equipment stress, and support continuous operations, protecting both people and assets.



LASER & MACHINE TOOLS



Precision thermal control that improves product accuracy, extends equipment lifespan, and reduces rejects. Friulair chillers help manufacturers meet tight tolerances and achieve higher output in advanced machining and laser applications.

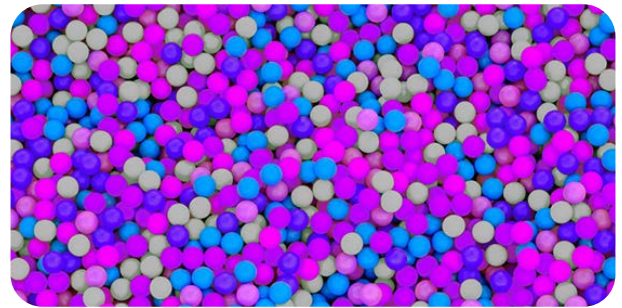

PLASTICS



Efficient cooling for molding and extrusion processes. By reducing cycle times and ensuring consistent quality, Friulair chillers help plastic manufacturers boost throughput and cut production costs.



HYDROGEN



Advanced thermal management for hydrogen production, compression, and storage. Friulair chillers increase process safety, improve system efficiency, and support sustainable energy applications in this fastgrowing sector.



BIOGAS



Cooling and dehumidification solutions that remove moisture and contaminants, improving biogas calorific value and protecting downstream equipment. Friulair chillers help operators maximize energy output and extend plant reliability.

Friulair Chiller Selection by Application

APPLICATION SECTORS FOR CHILLER SERIES	INFINITY COOL	ACW	FQBS	FQBE	FCWV	CDC	QBE TOTEM	TGR
BREWERIES								
WINERIES								
FOOD & BEVERAGE								
LABORATORIES & PHARMACEUTICAL								
AIR CONDITIONING & DATA CENTERS								
OIL & GAS								
LASER & MACHINE TOOLS								
PLASTICS								
HYDROGEN								
BIOGAS								



PRODUCT GUIDE



INFINITY COOL **NEW** P.12

Liquid chillers from 20 to 600 kW with R454B refrigerant



ACW **COMPACT** P.28

Liquid chillers 1 and 2 kW



QBS **COMPACT** P.30

Liquid chillers 1 and 2 kW



FQBE **MULTIPURPOSE** P.32

Liquid chillers from 2 to 25 kW with eco-friendly R513A refrigerant



FCWV **SCREW** P.36

Liquid chillers from 280 to 1200 kW with screw compressors and R513A refrigerant



CDC **DRYCOOLER** P.42

Drycoolers from 300 to 1200 kW (in Free-Cooling mode)



QBE TOTEM **LASER** P.46

Liquid chillers from 12 to 50 kW with dual circuit for laser machines



TGR **PLASTIC** P.50

Thermochillers from 8 to 21 kW for injection molding with R513A refrigerant

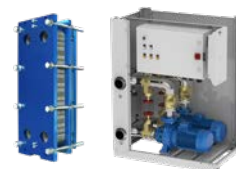

BEYOND CHILLERS P.54

System Completion Solutions
Service and Support
Compressed Air Solutions

OUR PRODUCTS

INFINITY COOL



THE NEW GENERATION OF FRIULAIR INDUSTRIAL CHILLERS

NEW

R454B

Innovation, Power, And Connectivity: The Future Starts Here.

INFINITY COOL is Friulair's new liquid chiller range, developed to meet the current and future needs of industry. Covering cooling capacities from 20 to 600 kW, it represents a generational leap in our product offering, thanks to advanced technical solutions, intelligent new controls, and a concrete

focus on environmental sustainability. Designed with the low-GWP refrigerant R454B, INFINITY COOL combines robust construction, ease of maintenance, and advanced electronic technologies, fully aligned with the latest directives on cybersecurity and energy efficiency.



INFINITY COOL **NEW**

Liquid chillers from 20 to 600 kW with R454B refrigerant

Power And Application Versatility

The **Infinity Cool** range spans cooling capacities from 20 to 600 kW and is designed to adapt to a wide variety of applications, with two dedicated configurations available on request:

WLT (Water Low Temperature)

Configuration for low-temperature water cooling, with nominal conditions @35/12/7 °C and @35/-4/-8 °C.

WHT (Water High Temperature)

Configuration for high-temperature water cooling, with nominal conditions @35/12/7 °C and @25/20/15 °C.



Advanced Electronic Controller

The **Infinity Cool** range is equipped with a state-of-the-art electronic controller, designed for top performance, seamless integration, and secure operation.

RS485 port with Modbus RTU protocol for traditional industrial environments

Native compatibility with Modbus TCP, BACnet/IP, MQTT, SNMP for modern connectivity and IoT systems

IEC 62443-4-1 cybersecurity certification, compliant with EU directives CRA (Cyber Resilience Act) and NIS2

Dedicated software tools simplify configuration, monitoring, and integration into automation systems



Refrigerant R454B – Low GWP Solution (467)

- Safety class A2L
- Low environmental impact
- Components engineered to ensure maximum operator safety: specific devices include refrigerant leak detectors, safety valves, and emergency ventilation systems (IFC 021–200 kW).

The Infinity Cool range is for outdoor use only



Infinity Core Software

The system is powered by **Infinity Core**, Friulair’s proprietary software developed in-house. It represents the intelligent heart of the range:

Optimizes performance in all conditions

Simplifies operational management

Enables smart logic and predictive diagnostics

**TOTAL CONTROL.
TRUE SECURITY.
SMART CONNECTIVITY.**

Infinity Cool Main Components



EVAPORATOR 01

Brazed plate heat exchanger: compact, high-performance design for excellent efficiency even at low operating temperatures.

COMPRESSORS 02

High-efficiency scroll compressors, designed to ensure reliability and low noise levels even under demanding conditions. Ideal for partial-load applications, with integrated thermal protections.

ELECTRONIC EXPANSION VALVE

Modulating design that adjusts refrigerant flow precisely according to thermal demand, improving efficiency and reducing energy consumption.

FILTER DRIER AND SIGHT GLASS

Replaceable solid-core filter system to guarantee refrigerant purity, with integrated visual indicator for humidity and charge monitoring.

SAFETY DEVICES

Comprehensive hydraulic and refrigeration protections, including high-pressure switches and safety valves, ensures safe operation of the unit.

FANS

03

All units feature EC electronic fans as standard, delivering intelligent airflow regulation, superior energy efficiency, and quiet operation. Integrated electronic control ensures optimal performance and reliability in all conditions.

CONDENSERS

04

Microchannel coils in aluminum alloy: reduced refrigerant charge, lightweight, corrosion-resistant, and optimized for outdoor environments.



BUFFER TANK
(OPTIONAL)

05

Painted steel tank, pressure-tested, designed to ensure thermal stability and reduce compressor cycling under short load conditions.

EXPANSION VESSEL

06

Supplied with optional pressurized tanks. Membrane expansion vessel with pre-charged air chamber, designed to absorb fluid volume variations in closed circuits and protect the system from overpressure.

CIRCULATION PUMP

07

Stainless steel centrifugal pumps, available in different configurations to match system head requirements.

Technical Data IFC 021÷041

INFINITY COOL MODELS		IFC021	IFC026	IFC035	IFC036	IFC040	IFC041
PERFORMANCES [1]							
Cooling capacity	[kW]	20.09	25.25	35.56	33.52	42.17	37.99
Compressors power input	[kW]	6.21	8.45	14.27	11.07	16.42	12.38
Total power input	[kW]	6.99	9.23	15.09	11.89	17.18	13.15
Total absorbed current	[A]	13.01	17.04	27.08	21.09	31.87	24.03
Energy efficiency [2]	EER	2.87	2.74	2.36	2.82	2.45	2.89
Seasonal energy efficiency [2,5]	SEPR HT	5.17	5.04	5.51	5.05	5.58	5.14
Heat transfer fluid flow rate	[dm ³ /h]	3450.07	4337.67	6108.58	5757.36	7243.83	6524.57
Pressure drop	[kPa]	18.5	26.6	52.3	45.9	37.4	30.3
ELECTRICAL DATA [2,3]							
Maximum power input (total)	[kW]	9.64	12.36	18.63	15.84	21.12	17.75
Maximum absorbed current (total)	[A]	16.60	21.18	32.10	26.54	37.39	30.42
Starting current	[A]	99.55	143.55	130.10	160.00	179.39	199.00
Fan power	[kW]	0.78	0.78	0.82	0.82	0.77	0.77
Fan current	[A]	1.34	1.34	1.39	1.39	1.30	1.30
Fans quantity	[#]	1	1	1	1	1	1
Power supply	[V/Ph/Hz]	400/3/50					
IP protection degree	---	IP54					
TECHNICAL DATA							
Refrigerant	---	R454B					
Compressor type	---	Scroll					
Evaporator type	---	Brazen plates					
Condenser type	---	Microchannel					
Compressors quantity	[#]	1	1	2	1	2	1
Refrigeration circuits quantity	[#]	1	1	1	1	1	1
Air flow	[m ³ /h]	8 875	8 875	12 453	12 453	12 944	12 944
Sound pressure level [4]	[dBA]	59.5	59.5	55.5	55.5	56.5	56.5
Water connections size (grooved)	[inch]	1" 1/2	1" 1/2	1" 1/2	1" 1/2	1" 1/2	1" 1/2
Tank capacity	[dm ³ /h]	110	110	110	110	200	200
Expansion vessel capacity	[dm ³ /h]	5	5	5	5	8	8

Notes:

- [1] Data referred to: water temp. in/out: 12/7°C ambient air temp. 35°C
- [2] Data referred to the unit without pump.
- [3] Data related to the heaviest condition allowed without the intervention of the safety devices.
- [4] Data referred to 10m and at an height of 1,5 m in open field.
- [5] Data in accordance with European Regulation (EU) 2016/2281 for eco-design requirements.

Technical Data IFC 050÷105

INFINITY COOL MODELS		IFC050	IFC051	IFC055	IFC065	IFC070	IFC090	IFC105
PERFORMANCES [1]								
Cooling capacity	[kW]	50.18	50.05	54.17	66.35	71.09	86.48	104.09
Compressors power input	[kW]	17.82	16.89	21.14	21.96	25.34	30.75	40.02
Total power input	[kW]	18.55	17.63	21.87	23.50	26.88	32.25	41.85
Total absorbed current	[A]	33.89	29.87	38.74	41.82	48.88	55.90	70.76
Energy efficiency [2]	EER	2.70	2.84	2.48	2.82	2.64	2.68	2.49
Seasonal energy efficiency [2,5]	SEPR HT	5.80	5.03	5.68	5.82	5.66	5.65	5.56
Heat transfer fluid flow rate	[dm ³ /h]	8619.31	8596.93	9303.72	11396.62	12210.22	14853.67	17878.14
Pressure drop	[kPa]	37.9	36.4	43.8	42.2	48.1	19.7	27.6
ELECTRICAL DATA [2,3]								
Maximum power input (total)	[kW]	24.08	23.39	27.09	31.23	35.05	40.69	51.45
Maximum absorbed current (total)	[A]	41.26	38.22	45.88	52.08	59.84	67.64	84.35
Starting current	[A]	183.26	229.00	192.88	210.08	256.84	327.64	344.35
Fan power	[kW]	0.73	0.73	0.73	1.54	1.54	1.49	1.83
Fan current	[A]	1.24	1.24	1.24	2.60	2.60	2.52	3.04
Fans quantity	[#]	1	1	1	1	1	1	1
Power supply	[V/Ph/Hz]	400/3/50						
IP protection degree	---	IP54						
TECHNICAL DATA								
Refrigerant	---	R454B						
Compressor type	---	Scroll						
Evaporator type	---	Brazen plates						
Condenser type	---	Microchannel						
Compressors quantity	[#]	2	1	2	2	2	2	2
Refrigeration circuits quantity	[#]	1	1	1	1	1	1	1
Air flow	[m ³ /h]	13 226	13 226	13 226	21 439	21 439	22 158	26 519
Sound pressure level [4]	[dBA]	57.5	58	57.5	60.5	60.5	61	60
Water connections size (grooved)	[inch]	1" 1/2	1" 1/2	1" 1/2	2"	2"	2" 1/2	2" 1/2
Tank capacity	[dm ³ /h]	200	200	200	200	200	400	400
Expansion vessel capacity	[dm ³ /h]	8	8	8	8	8	12	12

Notes:

- [1] Data referred to: water temp. in/out: 12/7°C ambient air temp. 35°C
- [2] Data referred to the unit without pump.
- [3] Data related to the heaviest condition allowed without the intervention of the safety devices.
- [4] Data referred to 10m and at an height of 1,5 m in open field.
- [5] Data in accordance with European Regulation (EU) 2016/2281 for eco-design requirements.

Technical Data IFC 110÷250

INFINITY COOL MODELS		IFC110	IFC125	IFC150	IFC175	IFC200	IFC225	IFC250
PERFORMANCES [1]								
Cooling capacity	[kW]	109.73	129.67	156.24	188.73	208.61	225.59	253.48
Compressors power input	[kW]	30.24	38.20	52.95	54.19	62.17	64.04	75.87
Total power input	[kW]	33.52	41.48	56.23	59.10	67.08	70.60	82.43
Total absorbed current	[A]	57.46	71.88	92.20	99.96	115.49	121.65	143.25
Energy efficiency [2]	EER	3.27	3.13	2.78	3.19	3.11	3.20	3.08
Seasonal energy efficiency [2.5]	SEPR HT	5.93	5.86	5.55	6.02	5.90	5.64	5.56
Heat transfer fluid flow rate	[dm ³ /h]	18847.38	22272.71	26835.47	32416.50	35830.41	38747.31	43537.27
Pressure drop	[kPa]	21.0	25.8	28.7	32.3	35.0	30.6	38.5
ELECTRICAL DATA [2.3]								
Maximum power input (total)	[kW]	48.38	57.71	73.31	83.01	90.76	101.43	115.43
Maximum absorbed current (total)	[A]	79.05	95.25	120.43	137.80	151.86	166.20	190.50
Starting current	[A]	306.05	355.25	414.43	526.80	540.86	732.19	805.11
Fan power	[kW]	1.64	1.64	1.64	1.64	1.64	1.64	1.64
Fan current	[A]	2.55	2.55	2.55	2.54	2.54	2.55	2.55
Fans quantity	[#]	2	2	2	3	3	4	4
Power supply	[V/Ph/Hz]	400/3/50						
IP protection degree	---	IP54						
TECHNICAL DATA								
Refrigerant		R454B						
Compressor type		Scroll						
Evaporator type		Brazen plates						
Condenser type		Microchannel						
Compressors quantity	[#]	2	2	2	2	2	4	4
Refrigeration circuits quantity	[#]	1	1	1	1	1	2	2
Air flow	[m ³ /h]	41 844	41 844	41 844	62 901	62 901	83 689	83 689
Sound pressure level [4]	[dBA]	59.2	59.2	64.5	64.8	64.8	62.2	62.2
Water connections size (grooved)	[inch]	2" 1/2	2" 1/2	2" 1/2	3"	3"	3"	3"
Tank capacity	[dm ³ /h]	250	250	250	450	450	300	300
Expansion vessel capacity	[dm ³ /h]	8	8	8	18	18	12	12

Notes:

- [1] Data referred to: water temp. in/out: 12/7°C ambient air temp. 35°C
- [2] Data referred to the unit without pump.
- [3] Data related to the heaviest condition allowed without the intervention of the safety devices.
- [4] Data referred to 10m and at an height of 1,5 m in open field.
- [5] Data in accordance with European Regulation (EU) 2016/2281 for eco-design requirements.

Technical Data IFC 275÷600

INFINITY COOL MODELS		IFC275	IFC300	IFC350	IFC400	IFC470	IFC540	IFC600
PERFORMANCES [1]								
Cooling capacity	[kW]	280.64	304.17	350.57	405.41	483.65	537.48	587.47
Compressors power input	[kW]	90.01	104.81	100.30	123.37	143.55	166.97	191.23
Total power input	[kW]	96.57	111.37	110.14	133.20	156.67	180.08	204.34
Total absorbed current	[A]	162.06	182.88	184.21	229.72	257.72	304.04	350.81
Energy efficiency [2]	EER	2.91	2.73	3.18	3.04	3.09	2.98	2.87
Seasonal energy efficiency [2,5]	SEPR HT	5.79	5.61	5.72	6.14	6.17	6.17	6.18
Heat transfer fluid flow rate	[dm ³ /h]	48202.14	52244.78	60213.78	69634.07	83071.67	92317.79	100903.80
Pressure drop	[kPa]	28.8	33.7	35.5	47.2	36.6	45.0	53.6
ELECTRICAL DATA [2,3]								
Maximum power input (total)	[kW]	131.02	146.61	158.26	181.52	223.82	247.07	270.33
Maximum absorbed current (total)	[A]	215.68	240.86	261.53	303.72	367.89	410.09	452.28
Starting current	[A]	914.65	990.18	1133.98	1260.57	2027.85	2333.83	2544.82
Fan power	[kW]	1.64	1.64	1.64	1.64	1.64	1.64	1.64
Fan current	[A]	2.55	2.55	2.55	2.55	2.55	2.55	2.55
Fans quantity	[#]	4	4	6	6	8	8	8
Power supply	[V/Ph/Hz]	400/3/50						
IP protection degree	---	IP54						
TECHNICAL DATA								
Refrigerant		R454B						
Compressor type		Scroll						
Evaporator type		Brazen plates						
Condenser type		Microchannel						
Compressors quantity	[#]	4	4	4	4	6	6	6
Refrigeration circuits quantity	[#]	2	2	2	2	2	2	2
Air flow	[m ³ /h]	83 689	83 689	125 533	125 533	167 377	167 377	167 377
Sound pressure level [4]	[dBA]	65.6	67.6	67.8	67.8	69.5	69.5	69.5
Water connections size (grooved)	[inch]	4"	4"	4"	4"	5"	5"	5"
Tank capacity	[dm ³ /h]	300	300	500	500	500	500	500
Expansion vessel capacity	[dm ³ /h]	12	12	18	18	18	18	18

Notes:

- [1] Data referred to: water temp. in/out: 12/7°C ambient air temp. 35°C
- [2] Data referred to the unit without pump.
- [3] Data related to the heaviest condition allowed without the intervention of the safety devices.
- [4] Data referred to 10m and at an height of 1,5 m in open field.
- [5] Data in accordance with European Regulation (EU) 2016/2281 for eco-design requirements.

Dimensions IFC 021÷041

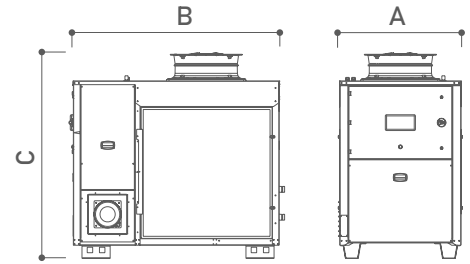

MODELS	IFC021	IFC026	IFC035	IFC036	IFC040	IFC041
NET DIMENSIONS & WEIGHT*						
Width A [mm]	1 000	1 000	1 000	1 000	1 000	1 000
Depth B [mm]	1 700	1 700	1 700	1 700	2 100	2 100
Height C [mm]	1 690	1 690	1 770	1 770	1 770	1 770
Weight [kg]	320	330	400	345	450	380

Note:

[*] For information on the packaged product (dimensions, weights and packaging type), please contact our sales department.

Dimensions IFC 050÷105

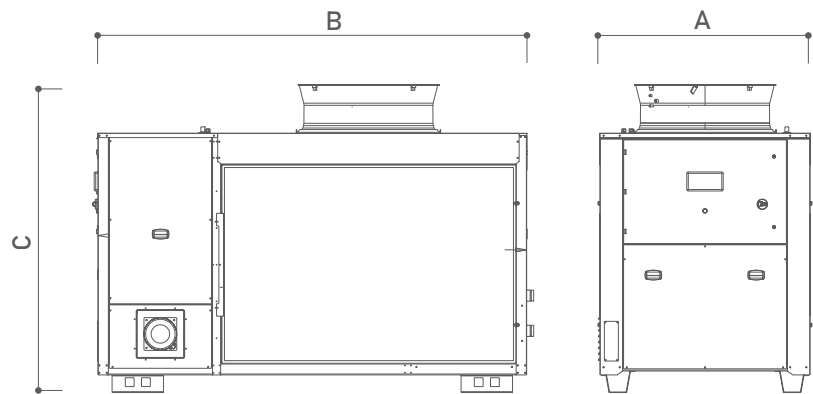

MODELS	IFC050	IFC051	IFC055	IFC065	IFC070	IFC090	IFC105
NET DIMENSIONS & WEIGHT*							
Width A [mm]	1 430	1 430	1 430	1 430	1 430	1 430	1 430
Depth B [mm]	2 400	2 400	2 400	2 400	2 400	2 920	2 920
Height C [mm]	2 070	2 070	2 070	2 110	2 110	2 110	2 110
Weight [kg]	600	575	605	620	650	750	790

Note:

[*] For information on the packaged product (dimensions, weights and packaging type), please contact our sales department.

Dimensions IFC 110÷200

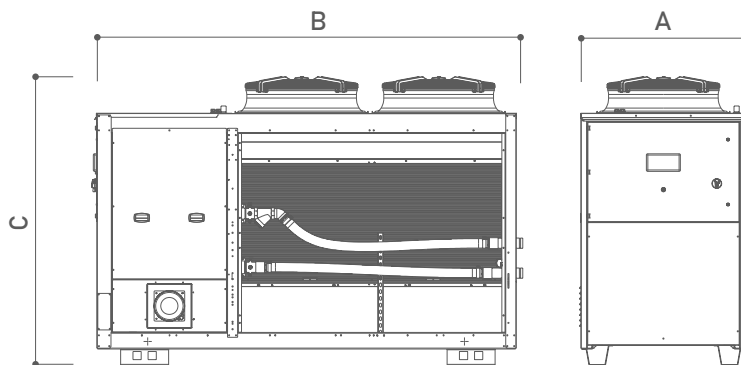

MODELS	IFC110	IFC125	IFC150	IFC175	IFC200
NET DIMENSIONS & WEIGHT*					
Width A [mm]	1 205	1 205	1 205	1 205	1 205
Depth B [mm]	3 143	3 143	3 143	4 142	4 142
Height C [mm]	2 132	2 132	2 132	2 132	2 132
Weight [kg]	1 075	1 075	1 075	1 305	1 305

Note:

[*] For information on the packaged product (dimensions, weights and packaging type), please contact our sales department.

Dimensions IFC 225÷600

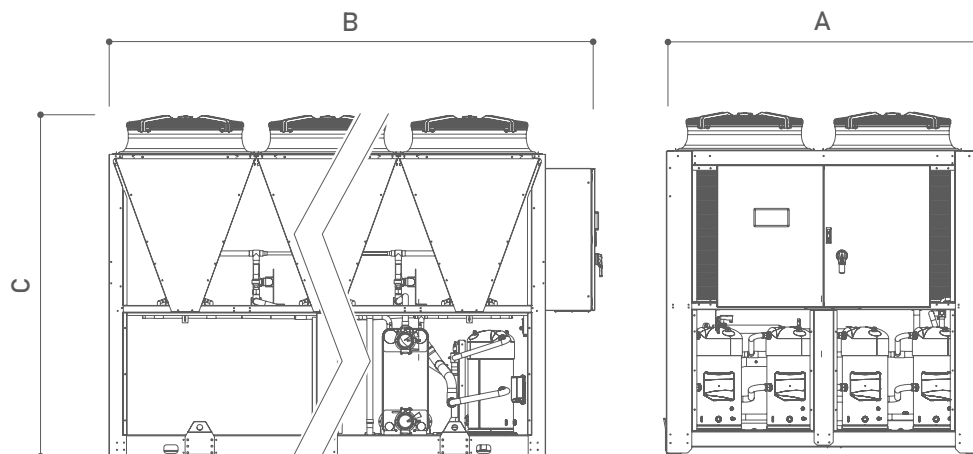

MODELS	IFC225	IFC250	IFC275	IFC300	IFC350	IFC400	IFC470	IFC540	IFC600
NET DIMENSIONS & WEIGHT*									
Width A [mm]	2 212	2 212	2 212	2 212	2 212	2 212	2 212	2 212	2 212
Depth B [mm]	2 424	2 424	2 424	2 424	3 419	3 419	4 419	4 419	4 419
Height C [mm]	2 408	2 408	2 408	2 408	2 408	2 408	2 408	2 408	2 408
Weight [kg]	1 750	1 750	1 750	1 750	2 115	2 115	2 958	2 958	2 958

Note:

[*] For information on the packaged product (dimensions, weights and packaging type), please contact our sales department.

Versions for all models

VERSION	CODE
Low water temperature (35/-4/-8 - 35/12/7 °C)	WLT
High water temperature (35/12/7 - 25/20/15 °C)	WHT

Options for IFC 021 ÷ 105

REFRIGERANT CIRCUIT OPTIONS	
Variable heat recovery	HRV
Condenser anti-corrosion treatment E-Coating (>3000hrs SWAAT test ASTM G85 A3)	OEC
Low ambient temperature kit (minimum ambient temperature -20°C)	CL
HYDRAULIC CIRCUIT OPTIONS	
Single pump 2,2bar residual head pressure	P2
Single pump 3,2bar residual head pressure	P3
Single pump 5,0bar residual head pressure	P5
Double pump 2,2bar residual head pressure (shut-off valves included)	D2
Double pump 3,2bar residual head pressure (shut-off valves included)	D3
Double pump 5,0bar residual head pressure (shut-off valves included)	D5
Disconnecter tank with P2 Pump (pressurized carbon steel tank included)	X2
Disconnecter tank with P3 Pump (pressurized carbon steel tank included)	X3
Disconnecter tank with P5 Pump (pressurized carbon steel tank included)	X5
Single pump shut-off valve	VSP1
Water filter shut-off valves	VSF
Pressurized water tank	TP
Atmospherical water tank (stainless steel)	TAIX
Evaporator anti-freeze heater	RA1
Evaporator and pumps anti-freeze heaters	RA2
Evaporator, pumps and tank anti-freeze heaters	RA3
ELECTRICAL CONTROL PANEL OPTIONS	
Compressors soft-starters	SFS
Control panel anti-condensate heater	RS
MISCELLANEOUS OPTIONS	
Compressors acoustic shields	AI1
LOOSE SUPPLIED OPTIONS	
Rubber anti-vibration mount (for units without water tank)	FA1
Rubber anti-vibration mount (for units with water tank)	FA2
Flanged water connections kit (EN1092-1) *	WC1
Threaded water connections kit (GAS) *	WC2
Flanged water Connections kit (ASME) *	WC3
Threaded water connections kit (NPT) *	WC4
Automatic water filling (pressurized systems)	WF
Automatic water filling (atmospherical systems)	WFA
Remote panel for electronic controller	ER
PACKAGING OPTIONS	
Barrier bag	PBB
Wooden base	PWB
Wooden crate	PWC

Options for IFC 110 ÷ 600

REFRIGERANT CIRCUIT OPTIONS	
Partial heat recovery (Desuperheater)	HRP
Total heat recovery	HRF
Condenser anti-corrosion treatment E-Coating (>3000hrs SWAAT test ASTM G85 A3)	OEC
Low ambient temperature kit (minimum ambient temperature -20°C)	CL
HYDRAULIC CIRCUIT OPTIONS	
Single pump 1,2bar residual head pressure	P1
Single pump 2,2bar residual head pressure	P2
Single pump 4,0bar residual head pressure	P4
Double pump 1,2bar residual head pressure (shut-off valves included)	D1
Double pump 2,2bar residual head pressure (shut-off valves included)	D2
Double pump 4,0bar residual head pressure (shut-off valves included)	D4
Single pump shut-off valve	VSP1
Water filter shut-off valves (Only for IFC 110 to 200)	VSF
Pressurized water tank	TP
Atmospherical water tank (stainless steel) (Only for IFC 110 to 200)	TAIX
Evaporator anti-freeze heater	RA1
Evaporator and pumps anti-freeze heaters	RA2
Evaporator, pumps and tank anti-freeze heaters	RA3
ELECTRICAL CONTROL PANEL OPTIONS	
Compressors soft-starters	SFS
Control panel anti-condensate heater	RS
MISCELLANEOUS OPTIONS	
Compressors acoustic shields	AI1
Condensers air filters	FP
Anti-intrusion grilles	GA
LOOSE SUPPLIED OPTIONS	
Rubber anti-vibration mount (for units without water tank)	FA1
Rubber anti-vibration mount (for units with water tank)	FA2
Flanged water connections kit (EN1092-1) *	WC1
Threaded water connections kit (GAS) *	WC2
Flanged water Connections kit (ASME) *	WC3
Threaded water connections kit (NPT) *	WC4
Automatic water filling	WF
Remote panel for electronic controller	ER
PACKAGING OPTIONS	
Container loading (Only for IFC 225 to 600)	PCL
Barrier bag	PBB
Wooden base (Only for IFC 110 to 200)	PWB
Wooden crate	PWC

Note:

[*] Also available in stainless steel version.

Hydraulic Configuration Examples



IFC 150 P4 with single pump 4,0 bar residual head pressure



IFC 150 P4 + VSP with single pump 4,0 bar residual head pressure and pump shut-off valve



IFC 150 D4 with double pump 4,0 bar residual head pressure and shut-off valves included



IFC 150 D4 + TP with double pump 4,0 bar residual head pressure, shut-off valves included and pressurized water tank



IFC 150 P4 + TP with single pump 4,0 bar residual head pressure and pressurized water tank

FOCUS

Maximum efficiency is ensured thanks to optional smart heat recovery systems, fully integrated into the unit through a 3-way valve, secondary heat exchanger, dual hydraulic line, and check valve.



MODELS	OPTIONS AVAILABLE	CODE
IFC 021 ÷ 105	Variable heat recovery	HRV
IFC 110 ÷ 600	Partial heat recovery (Desuperheater)	HRP
	Total heat recovery	HRF

Operating Limits



Refer to the most recent version of the technical manual for operating limits of the range.
Contact the company.

Main Applications



Insights Applications Sectors >> p.7

ACW

COMPACT

LIQUID CHILLERS 1 AND 2 KW

The ACW series is designed for process cooling in applications where water must be maintained at a temperature no lower than ambient. These are extremely compact units, ideal for direct integration with welders, spindles, and small industrial

equipment. The integrated electronics provide precise temperature control and simple alarm management. With their lightweight design (only 19–26 kg) and compact dimensions, they are easy to transport and install.



ACW Main Components

- | ON/OFF fans
- | Tube-and-fin heat exchanger
- | Plastic water tank
- | Peripheral pump
- | Water level indicator
- | Main switch

FOCUS

Thanks to the integrated stainless-steel tank and simplified control logic, ACW is the ideal choice for small systems that require reliability, precision, and fast plug & play start-up, even in industrial environments.



Available Option

- | Wheels kit - FW

Operating Limits

- | Ambient temperature: **from +5 °C to +40 °C**
- | Outlet water temperature: **from +5 °C to +55 °C**

Main Applications



Insights Applications Sectors >> p.7

Technical Data

ACW MODELS		001	002
Cooling capacity	[kW]	0.66	1.41
Total power input	[kW]	0.2	0.2
Total absorbed current	[A]	1.25	1.35
Power supply	[V/ph/Hz]	230/1/50	230/1/50
IP protection degree	---	IP20	IP20
IP protection degree	[dm²]	2	2
Water connection size	[inch]	3/8" BSP G	3/8" BSP G

Dimensions

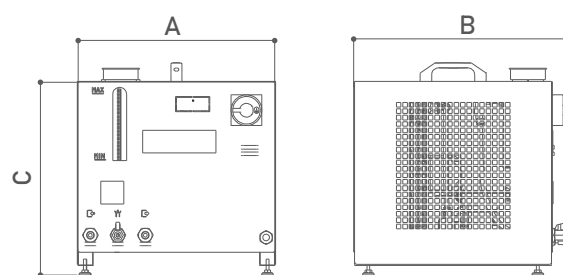

ACW MODELS		001	002
NET DIMENSIONS & WEIGHT			
Width A	[mm]	430	430
Depth B	[mm]	470	470
Height C	[mm]	460	460
Weight	[kg]	19.4	26
GROSS DIMENSIONS & STANDARD PACKING			
Width A	[mm]	600	600
Depth B	[mm]	580	580
Height C	[mm]	580	580
Weight	[kg]	25.8	33
Packaging	Treated wooden pallet + cardboard box		

QBS

COMPACT

LIQUID CHILLERS 1 AND 2 KW

The QBS range is Friulair's compact liquid chiller solution, designed to ensure reliable performance and high efficiency in reduced dimensions for industrial use.

QBS chillers integrate compressor, pump, tank, and condenser into a single compact, ready-to-use unit, ideal for applications requiring precise,

localized, and continuous cooling. The range includes two models optimized for maximum cooling capacity with a minimal footprint.

Using R134a refrigerant, QBS units combine proven reliability, ease of installation, and low maintenance, making them a dependable solution for a wide variety of industrial applications.



QBS Main Components

- | Reciprocating compressor
- | Copper tube and fin evaporator, immersed in an open tank
- | Condenser with copper tubes and aluminum fins
- | Axial fans
- | Filter drier
- | Capillary refrigerant expansion device
- | Insulated stainless-steel tank
- | Peripheral pump
- | Water level indicator
- | Water filling system

FOCUS

The QBS units are built in steel with RAL9005 powder coating, making them suitable for indoor installation.

The microprocessor controller regulates the outlet water temperature, manages compressor operation, and handles alarms with ease.

QBS Electronic Controller Display



Available Option

- | Wheels kit - FW

Operating Limits

- | Ambient temperature: **from +10 °C to +40 °C**
- | Outlet water temperature: **from +5 °C to +25 °C**

Main Applications



Insights Applications Sectors >> p.7

Technical Data

QBS MODELS [*]		001	002
PERFORMANCES [1]			
Cooling capacity	[kW]	0.94	1.41
Compressors power input	[kW]	0.25	0.42
Total power input	[kW]	0.50	0.71
Total absorbed current	[A]	3.43	4.00
Energy efficiency (pump excluded)	EER	3.09	2.77
Seasonal energy performance ratio [*]	SEPR HT	Out of ErP scope [4]	
Water flow	[l/h]	161.06	242.58
Available pressure	[kPa]	279	224
ELECTRICAL DATA [2]			
Maximum power input (total)	[kW]	0.80	1.00
Maximum absorbed current (total)	[A]	6.00	5.10
Starting current	[A]	18.80	21.50
Fan power	[kW]	0.05	0.09
Fan current	[A]	0.34	0.55
Fans quantity	[#]	1	1
Pump power input	[kW]	0.2	0.2
Pump absorbed current	[A]	0.92	0.92
Power supply	[V/Ph/Hz]	230/1/50	230/1/50
IP protection degree	---	IP20	IP20
TECHNICAL DATA:			
Compressors quantity	[#]	1	1
Refrigerating circuit quantity	[#]	1	1
Air flow	[m³/h]	550	720
Sound pressure level [3]	[dBA]	41	42
Water connections size	[inch]	3/8" BSP G	3/8" BSP G
Tank capacity	[dm³]	15	15

Notes:

[*] Data in accordance with European Regulation (EU) 2016/2281 for eco-design requirements

[1] Data referred to: water temperature in/out: 20/15°C - ambient temperature 25°C

[2] Data referred to the worst conditions allowed by safety devices

[3] Data referred to 10m and at an height of 1,5 m in open field

[4] Data referred outlet water temperature +13°C

Dimensions

QBS MODELS		001	002
NET DIMENSIONS & WEIGHT			
Width	[mm]	470	470
Depth	[mm]	480	480
Height	[mm]	610	610
Weight	[kg]	40	40
GROSS DIMENSIONS & STANDARD PACKING			
Width	[mm]	600	600
Depth	[mm]	580	580
Height	[mm]	770	770
Weight	[kg]	49	49
Packaging		Treated wooden pallet + cardboard box	

FQBE

MULTIPURPOSE

R513A

LIQUID CHILLERS FROM 2 TO 25 KW WITH ECO-FRIENDLY R513A REFRIGERANT

The FQBE range is the natural evolution of the historic QBE series and fully complies with the latest and most stringent European regulations on environmental sustainability (EU Reg. 2016 / 2281 and F-Gas). By using R513A refrigerant, a low-GWP (631) gas that is completely non-flammable and non-toxic, FQBE units can be safely and confidently

installed indoors. Thanks to their compact design, excellent high energy efficiency, and advanced next-generation components, the FQBE models deliver consistent, reliable performance and outstanding versatility across a wide range of demanding industrial applications.



FQBE Key Features

- | Eco-friendly R513A refrigerant
- | High energy efficiency (SEPR HT up to 5.98 in models 008 ÷ 020)
- | Electronic fans as standard
- | High-performance industrial components
- | Industry 4.0 compatibility

FOCUS

By adopting R513A refrigerant, Friulair anticipates the stricter requirements introduced by the new EU F-Gas Regulation (2024/573), significantly reducing the environmental impact of its machines. With a GWP of 631, around 64% lower than R407C, the FQBE series represents a sustainable, forward-looking solution for tomorrow's applications. The updated F-Gas framework, driven by international agreements to curb greenhouse gas emissions, enforces an accelerated "Phase-Down" of fluorinated gases. Quotas expressed in CO₂ equivalent (GWP × mass) will drop from the 2015 baseline to just 5.2% by 2030, paving the way for innovative technologies like those adopted by Friulair.

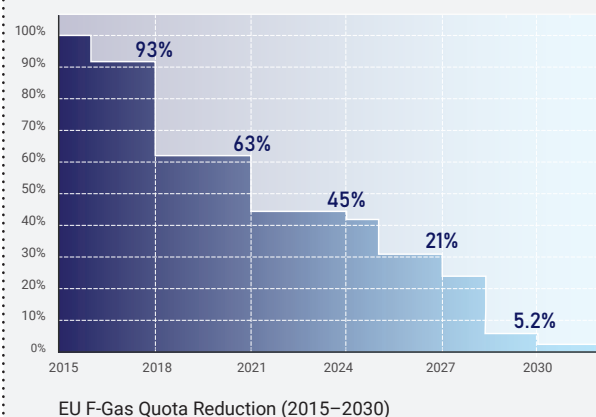

Main Components

COMPRESSORS

rotary, reciprocating, and scroll. Extremely reliable and efficient, widely used in industrial cooling. The latest hermetic scroll generation ensures quiet operation without vibrations.

EVAPORATOR

- Copper coaxial type for models FQBE003 ÷ 006
- Brazed plate stainless-steel type for models FQBE008 ÷ 025, compact and high efficiency.

CONDENSER

full-aluminum microchannel type, reducing refrigerant charge. Polyester powder-coated for enhanced corrosion resistance.

FANS

variable-speed axial fans, directly coupled to external rotor motors.

REFRIGERATION CIRCUIT

includes expansion valve, pressure switches, filter drier, and sight glass.

HYDRAULIC CIRCUIT

integrated tank, hydraulic pump, vent and drain valve. All models feature non-ferrous hydraulic circuits and can operate with water/glycol mixtures.

ELECTRICAL PANEL

EN 60204 compliant, with main switch and numbered terminals.

ELECTRONIC CONTROLLER

microprocessor-based with intuitive interface, ready for Industry 4.0 integration.



FQBE Electronic Controller Display

Technical Data

FQBE MODELS:		003	005	006	008	009	012	014	020	025
PERFORMANCES 20/15@25 [1,3]										
Cooling capacity	[kW]	2.23	4.00	5.74	7.96	9.38	11.63	15.10	19.06	24.26
Compressors power input	[kW]	0.39	1.19	1.76	1.18	1.50	1.92	2.53	3.49	5.13
Total power input	[kW]	0.55	1.34	1.92	1.33	1.65	2.07	3.13	4.09	6.03
Total absorbed current	[A]	2.77	9.07	8.35	4.56	5.10	5.03	10.98	14.74	24.40
Energy efficiency	EER	4.07	2.98	2.99	5.99	5.70	5.61	4.83	4.67	4.02
Water flow	[l/h]	384	687	987	1 369	1 613	2 000	2 598	3 279	4 172
Evaporator pressure drop	[kPa]	21.0	6.9	13.7	26.0	35.0	27.1	26.0	39.7	42.4
PERFORMANCES 12/7@35 [2,3]										
Cooling capacity	[kW]				5.49	6.53	8.28	10.70	13.27	
Compressors power input	[kW]				1.36	1.69	2.16	2.85	3.88	
Total power input	[kW]				1.51	1.84	2.31	3.45	4.48	
Total absorbed current	[A]				4.73	5.28	5.33	11.37	15.00	
Energy efficiency	EER				3.63	3.55	3.58	3.11	2.96	
Seasonal energy performance ratio [*]	SEPR HT				5.56	5.59	5.98	5.32	5.02	
Water flow	[l/h]				944	1 123	1 423	1 840	2 282	
Evaporator pressure drop	[kPa]				13.3	18.2	14.6	13.9	20.5	
ELECTRICAL DATA [3]										
Maximum power input (total)	[kW]	0.93	2.01	2.94	2.65	3.24	4.05	5.78	7.10	9.62
Maximum absorbed current (total)	[A]	4.69	13.82	12.53	6.09	7.02	7.83	14.77	17.06	27.86
Starting current	[A]	24.30	50.80	86.80	46.59	46.59	40.59	65.35	101.35	149.53
Fan power	[kW]	0.16	0.16	0.16	0.15	0.15	0.15	0.60	0.60	0.90
Fan current	[A]	0.80	0.80	0.80	1.59	1.59	1.59	6.35	6.35	9.53
Fan quantity	[#]	1	1	1	1	1	1	1	1	1
Power supply	[V/Ph/Hz]	230/1/50			400/3/50					
IP protection degree	—	IP40			IP44					
TECHNICAL DATA:										
Refrigerant		R513A								
Compressor type		Rotary			Scroll					
Evaporator type		Braze plates								
Condenser type		Microchannel								
Compressor quantity	[#]	1	1	1	1	1	1	1	1	1
Refrigeration circuit quantity	[#]	1	1	1	1	1	1	1	1	1
Air flow	[m³/h]	2 200	2 500	2 500	4 800	4 800	5 000	5 500	5 500	5 500
Sound pressure level [4]	[dBA]	46	46	46	49	49	49	49	49	49
Water connections size	[inch]	1/2"	1/2"	1/2"	1"	1"	1"	1"	1"	1"
Tank capacity	[dm³]	25	25	25	90	90	90	90	90	90

Notes:

[*] With electronic fans, FQBE obtains performances in accordance with European Regulation (EU) 2016/2281 for eco-design requirements del Regolamento Europeo (UE) 2016/2281 per la progettazione ecocompatibile.

[1] Data referred to: water temp. in/out: 20/15°C - Ambient air temp. 25°C

[2] Data referred to: water temp. in/out: 12/7°C - Ambient air temp. 35°C

[3] Data referred to the unit without pump

[4] Data referred at 10 m in free field and 1,5 m height

Available Options

FQBE MODELS:	CODE	003-006	008-025
Leaving water temperature accuracy (+/- 0,1 K) electronic hot gas by-pass valve	VBE	o	o
Leaving water temperature accuracy (+/- 1 K) mechanical hot gas by-pass valve	VBM	o	o
P3 Pump	P3	STD	STD
P5 Pump	P5	o	o
Automatic water bypass valve	BA	o	o
Refrigerant gauges	GR	o	STD
Compressor crankcase heater	RC	STD	STD
Outdoor installation (min. ambient temperature +10°C)	FE	o	STD
Pressurized water tank with brazed plates evaporator	TP EXP	o	o
Non ferrous pressurized water tank with brazed plates evaporator (stainless steel tank)	TPI EXP	o	o
Without pump	P0	o	o
Without tank with brazed plates evaporator	T0 EXP	o	o
Continuous fan(s) speed control - phase cut type (minimum ambient temperature - 8.0°C)	CA	o	o
Continuous fan(s) speed control - electronic fan(s) (minimum ambient temperature -10.0°C)	CE	nd	o
Low ambient temperature kit (minimum ambient temperature -15°C)	CL	nd	o
Ductable axial electronic fan(s)	ZAP	nd	o
Condenser(s) air filter(s)	FP	o	STD
Automatic water filling kit for units with atmospheric water tank	WFA	nd	o
Electrical switchboard anti-condensation heater	RS	nd	o
Wind baffles kit	FWB	nd	o
Wheels kit	FW	o	o
RS485 serial port converter kit	EMB	o	o
Water check valve and interlocked solenoid valve [1]	VCI	o	o
Wooden Crate	PWC	o	o

Notes:

o : Optional accessory

STD : Standard accessory

nd : Accessory not available

[1] Only available with standard tank configuration, not available with TP / TPI / TA options.

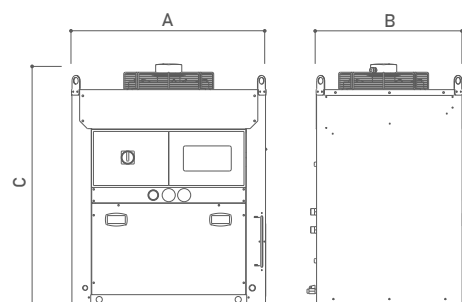

Dimensions

FQBE MODELS:	003	005	006	008	009	012	014	020	025
NET DIMENSIONS & WEIGHT *									
Width A	720	720	720	1 004	1 004	1 004	1 004	1 004	1 004
Depth B	670	670	670	753	753	753	753	753	753
Height C	680	680	680	1 257	1 257	1 257	1 257	1 257	1 257
Weight	85	92	95	235	240	245	255	255	255

Note: [*] for information on the packaged product (dimensions, weights and packaging type), please contact the company.

Operating Limits



Refer to the most recent version of the technical manual for operating limits of the range. **Contact the company.**

Main Applications



Insights Applications Sectors >> p.7

FCWV

SCREW

R513A

**LIQUID CHILLERS FROM 280 TO 1200 KW
WITH SCREW COMPRESSORS
AND R513A REFRIGERANT**



FCWV Range Overview

The FCWV range is the evolution of the CWV series, designed to ensure high performance, energy efficiency, and long-term reliability. These chillers are ideal for medium and large scale industrial

applications, guaranteeing precise temperature control of the cooling fluid even under severe environmental conditions and during extended operating periods. The range is intended for outdoor installation.

Main Components

SCREW COMPRESSORS: quiet and efficient operation with stepless continuous control equipped as standard with shut-off valves.

SHELL-AND-TUBE EVAPORATOR: equipped with antifreeze protection and differential pressure switch.

AXIAL FANS: with continuous phase-cut regulation.

MICROCHANNEL CONDENSERS: resistant to galvanic corrosion.

ELECTRONIC CONTROLLER: intuitive interface with Modbus RTU.

STRUCTURE: galvanized steel with powder coating for durability.

FOCUS

Electrical Circuit and Electronic Controller

- Numbered electrical cables, probes, and transducers supplied as standard
- Fuses and thermal relay protection for compressors
- User interface with easy menu navigation, accessible on the front panel of the electrical cabinet
- Alarm history: up to 10 events stored on the Master Board (unlimited with optional remote communication gateway ENB)
- RS485 connection with MODBUS RTU protocol as standard

The electronic controller can manage up to four units in modular installation: one “Master” unit and up to three “Slave” units via RS485 serial connection.



CWV Electronic Controller Display

Technical Data FCWV 281÷521

FCWV MODELS [*]		281	282	331	332	381	382	451	452	521
PERFORMANCES [1]										
Cooling capacity	[kW]	263.57	251.47	314.87	303.57	371.97	370.07	434.65	425.03	501.51
Compressors power input	[kW]	102.12	94.73	115.42	110.52	125.94	135.19	140.31	143.43	157.59
Total power input	[kW]	109.32	101.93	124.42	119.52	136.74	145.99	152.91	156.03	171.99
Total absorbed current	[A]	186.08	175.31	208.26	203.03	226.41	251.67	259.14	266.46	289.79
Energy efficiency	EER	2.41	2.47	2.53	2.54	2.72	2.53	2.84	2.72	2.92
Seasonal energy efficiency [2]	SEPR HT	5.17	5.03	5.35	5.20	5.49	5.08	5.52	5.54	5.53
Water flow	[l/h]	45 334	43 252	54 158	52 214	63 979	63 652	74 761	73 105	86 259
Evaporator pressure drop	[kPa]	42.0	38.8	45.5	33.2	46.3	27.7	36.1	29.8	39.1
ELECTRICAL DATA [3]										
Maximum power input (total)	[kW]	134.75	132.20	152.99	152.32	172.65	185.38	200.28	205.50	226.56
Maximum absorbed current (total)	[A]	224.26	219.41	252.57	251.09	280.69	309.59	332.42	341.26	375.48
Starting current	[A]	356.60	280.51	455.50	364.29	488.40	480.49	613.30	498.28	681.20
Fan power	[kW]	1.80	1.80	1.80	1.80	1.80	1.80	1.80	1.80	1.80
Fan current	[A]	3.90	3.90	3.90	3.90	3.90	3.90	3.90	3.90	3.90
Fans quantity	[#]	4	4	5	5	6	6	7	7	8
Power supply	[V/Ph/Hz]	400/3/50	400/3/50	400/3/50	400/3/50	400/3/50	400/3/50	400/3/50	400/3/50	400/3/50
IP protection degree	—	IP54	IP54	IP54	IP54	IP54	IP54	IP54	IP54	IP54
TECHNICAL DATA										
Compressors quantity	[#]	1	2	1	2	1	2	1	2	1
Refrigeration circuits quantity	[#]	1	2	1	2	1	2	1	2	1
Air flow	[m ³ /h]	72 000	72 000	90 000	90 000	108 000	108 000	126 000	126 000	144 000
Sound pressure level [4]	[dBA]	59.5	59.5	60.5	60.5	61	61	62	62	62.5
Water connections size (grooved)	[inch]	5"	5"	5"	5"	5"	5"	5"	5"	5"

Notes:

[*] The data below refers to CWV models with R134a.

[1] Data referred to: water temp. in/out: 12/7°C ambient air temp. 35°C

[2] Data in accordance with European Regulation (EU) 2016/2281 for eco-design requirements.

[3] Data related to the heaviest condition allowed without the intervention of the safety devices.

[4] Data referred to 10m and at an height of 1,5 m in open field.

Technical Data FCWV 522÷1202

FCWV MODELS [*]		522	601	602	652	702	762	832	902	1052	1202
PERFORMANCES [1]											
Cooling capacity	[kW]	483.96	574.36	557.83	626.33	702.86	755.87	821.53	876.23	988.44	1151.58
Compressors power input	[kW]	159.09	195.34	188.39	218.69	243.87	253.80	270.52	284.66	309.58	399.40
Total power input	[kW]	173.49	211.54	204.59	236.69	263.67	275.40	293.92	309.86	338.38	431.80
Total absorbed current	[A]	300.11	358.37	347.54	396.73	438.51	455.75	492.39	524.80	570.63	731.08
Energy efficiency	EER	2.79	2.72	2.73	2.65	2.67	2.74	2.80	2.83	2.92	2.67
Seasonal energy efficiency [2]	SEPR HT	5.52	5.56	5.50	5.54	5.60	5.60	5.52	5.51	5.52	5.50
Water flow	[l/h]	83 242	98 790	95 946	107 729	120 892	130 010	141 303	150 712	170 011	198 072
Evaporator pressure drop	[kPa]	36.9	45.6	32.9	39.8	37.0	41.7	34.3	38.2	43.5	56.9
ELECTRICAL DATA [3]											
Maximum power input (total)	[kW]	238.56	274.70	272.27	305.99	325.04	344.09	372.33	400.57	453.13	549.40
Maximum absorbed current (total)	[A]	399.76	456.23	452.45	505.14	533.27	561.39	613.12	664.84	750.96	912.46
Starting current	[A]	529.48	952.10	679.78	708.07	753.08	769.09	917.91	945.72	1056.68	1408.33
Fan power	[kW]	1.80	1.80	1.80	1.80	1.80	1.80	1.80	1.80	1.80	1.80
Fan current	[A]	3.90	3.90	3.90	3.90	3.90	3.90	3.90	3.90	3.90	3.90
Fans quantity	[#]	8	9	9	10	11	12	13	14	16	18
Power supply	[V/Ph/Hz]	400/3/50									
IP protection degree	—	IP54	IP54	IP54	IP54	IP54	IP54	IP54	IP54	IP54	IP54
TECHNICAL DATA											
Compressors quantity	[#]	2	1	2	2	2	2	2	2	2	2
Refrigeration circuits quantity	[#]	2	1	2	2	2	2	2	2	2	2
Air flow	[m³/h]	144 000	162 000	162 000	180 000	198 000	216 000	234 000	252 000	288 000	324 000
Sound pressure level [4]	[dBA]	62.5	63.5	63.5	63.5	64	64	64.5	65	65.5	66.5
Water connections size (grooved)	[inch]	5"	5"	5"	6"	6"	6"	6"	6"	6"	8"

Notes:

[*] The data below refers to CWV models with R134a.

[1] Data referred to: water temp. in/out: 12/7°C ambient air temp. 35°C

[2] Data in accordance with European Regulation (EU) 2016/2281 for eco-design requirements.

[3] Data related to the heaviest condition allowed without the intervention of the safety devices.

[4] Data referred to 10m and at an height of 1,5 m in open field.

Available Options

FCWV OPTIONS	CODE
Evaporator anti-freeze heater	RA1
Electric switchboard anti-condensation heater	RS
Continuous fan(s) speed control - electronic fan(s) (min. ambient temp. -10.0°C)	CE
Gateway for remote communication	ENB
Control panel ventilation	EBV
Electronic controller sun/rain protection	SRP
Compressor(s) acoustic shield(s)	AI1
Condenser(s) air filter(s)	FP
Condenser anti-corrosion treatment Electrofin® type	OEC
Flanged water connections kit (EN1092-1)	WC1
Water connections kit to be brazed	WC5
Control panel roof kit	FPR
Rubber anti-vibration mountings kit	FA1
Remote panel kit	ER
Flow switch contact	FSC
Bacnet gateway kit	GBCN
Profibus gateway kit	GPFB
Profinet gateway kit	GPFN
Ethernet port [1]	ETP
Compressor(s) softstarter(s) [2]	SFS
Container loading	PCL
Barrier bag	PBB

Notes:

[1] Available only with the GBCN/GPFB/GPFN option.

[2] Not available on all models. Contact our company.

Tropicalized version on demand.

Dimensions FCWV 281÷1202

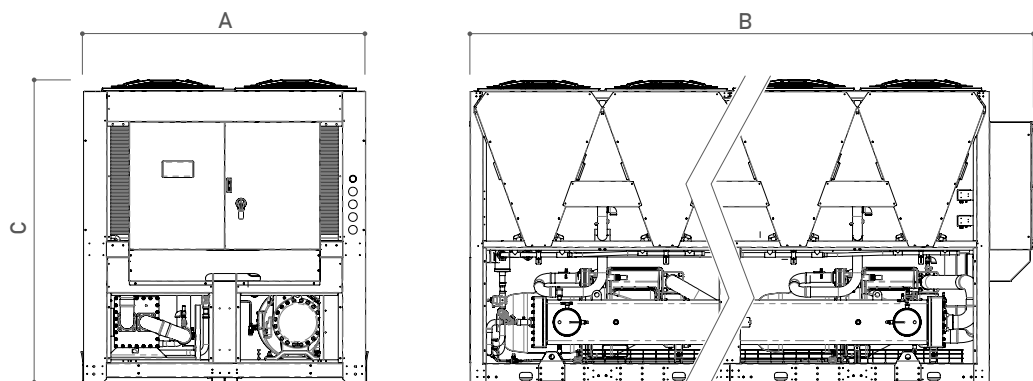

FCWV MODELS	281	282	331	332	381	382	451	452	521
Width A [mm]	2 250	2 250	2 250	2 250	2 250	2 250	2 250	2 250	2 250
Depth B [mm]	3 600	3 600	3 600	3 600	3 600	3 600	4 600	4 600	4 600
Height C [mm]	2 300	2 300	2 300	2 300	2 300	2 300	2 300	2 300	2 300
Weight [kg]	2 717	2 800	3 180	3 300	3 247	3 420	3 592	3 830	3 758

FCWV MODELS	522	601	602	652	702	762	832	902	1052	1202
Width A [mm]	2 250	2 250	2 250	2 250	2 250	2 250	2 250	2 250	2 250	2 250
Depth B [mm]	4 600	5 600	5 600	6 600	6 600	6 600	7 600	8 600	8 600	10 600
Height C [mm]	2 300	2 300	2 300	2 300	2 300	2 300	2 300	2 300	2 300	2 300
Weight [kg]	3 950	4 200	4 450	6 057	6 135	6 191	6 564	6 925	7 089	8 172

Note:

For information on the packaged product (dimensions, weights and packaging type), please contact the company.

Operating Limits



Refer to the most recent version of the technical manual for operating limits of the range. **Contact the company.**

Main Applications



Insights Applications Sectors >> p.7

CDC

DRYCOOLER

**DRYCOOLERS
FROM 300 TO 1200 KW
IN FREE-COOLING MODE**



CDC Range Overview

The CDC range includes air-cooled liquid coolers (drycoolers) designed for industrial and HVAC applications. They are ideal for closed-loop cooling of process fluids in the food, energy, manufacturing, and processing industries.

Available in 11 models from 300 to 1200 kW, the CDC series is divided into two configurations:

- CDC030–CDC060: horizontal layout
- CDC070–CDC120: compact “V-shaped”

Main Components

AXIAL FANS

Low-noise, optimized performance, with speed control (optional: EC or phase-cut regulation).

COIL HEAT EXCHANGERS

Copper tubes with aluminum fins. Rated for 6 bar. Anti-corrosion treatments available on request.

STRUCTURE

Galvanized and painted steel (RAL7035), robust and weather-resistant, suitable for outdoor installation.

FOCUS

Free Cooling Mode

When ambient temperature is low enough, the CDC dry cooler cools the fluid without using the refrigeration circuit, drastically reducing energy consumption.

Adiabatic version (optional)

Ideal for hot climates, offering:

- Higher performance in a compact footprint
- Lower water consumption compared to evaporative towers
- Longer service life for the associated chiller

CDC dry coolers can also be integrated with Friulair chillers in Free Cooling mode, delivering high energy efficiency during cooler seasons, when ambient temperatures allow the compressor to be bypassed.

The closed and pressurized hydraulic circuit reduces both maintenance costs and water consumption compared to evaporative towers, offering tangible sustainability benefits.

Dry coolers can also be selected for lower or higher capacities depending on the required fluid temperatures.



CDC Electronic Controller Display

ELECTRONIC CONTROLLER

Step-by-step or continuous fan management, with an intuitive interface.

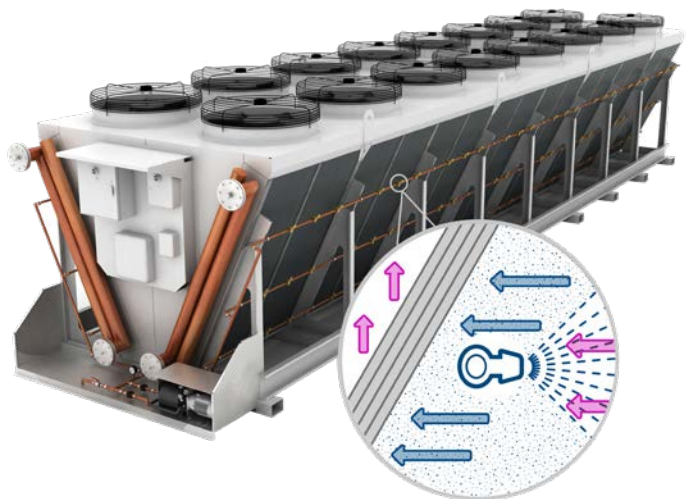

Adiabatic cooling lowers air temperature by spraying water, improving heat exchange through evaporation.

Technical Data

CDC MODELS		030	035	040	045	050	060	070	080	090	105	120
Cooling capacity	[kW]	321.9	356.4	394.2	450.1	528.7	628.2	717.2	794.1	890.4	1037.1	1259.3
Water flow	[m³/h]	59.9	66.4	73.4	83.8	98.4	117	133.5	147.8	165.7	193.1	232.4
Air flow	[m³/h]	86630	162000	128550	139100	143720	208630	241880	209750	239840	293130	322110
Pressure drop	[kPa]	74	64	37	54	44	60	82	66	84	77	65
N° of fans	[#]	4	6	6	6	6	8	10	8	10	14	14
Power consumption	[kW]	14.4	21.6	14.7	14.7	21.1	28.8	36	28.8	36	25.2	34.3
Absorbed current	[A]	28.8	43.2	31.2	31.2	43.2	57.6	72	57.6	72	54.6	72.8
Power input	[V/ph/Hz]	400/3/50										
IP grade	[#]	54	54	54	54	54	54	54	54	54	54	54
Sound pressure level	[dB]	65	67	61	61	67	68	68	67	68	59	63
Water connection	[inch]	3"	3"	4"	4"	4"	4"	4"	4"+4"	4"+4"	2x4"	2x4"

Notes:

Data referred to: water temp. IN: 15°C - Ambient air temp. 0°C - Ethylene glycol: 30%

Data referred to AC ON-OFF fans. Contact our sales offices to receive EC performance data and for any configuration different from the standard.

Available Options

CDC AVAILABLE MODELS

Horizontally mounted coils (standard, up to 600 kW)

Vertically mounted coil (on request up to 600 kW)

Compact "V" configuration (standard from 700 kW to 1200 kW)

Anti-corrosion coils treatment (optional)

CDC AVAILABLE ACCESSORIES

Fans cabling

Electrical panel

Water temperature control and microprocessor supervision directly mounted on the unit (*)

Fans speed regulator (cut-phase for AC fans and 0-10 VDC for Electronic fans)

Spray water kit for adiabatic systems

Special fan motors - IP55 and/or High-temperature motors

Safety isolating switch

Internet gateway for remote monitoring (**)

Notes:

(*) = available in the stand-alone version of CDC

(**) = only if CDC is purchased together with one of our chillers.

Dimensions

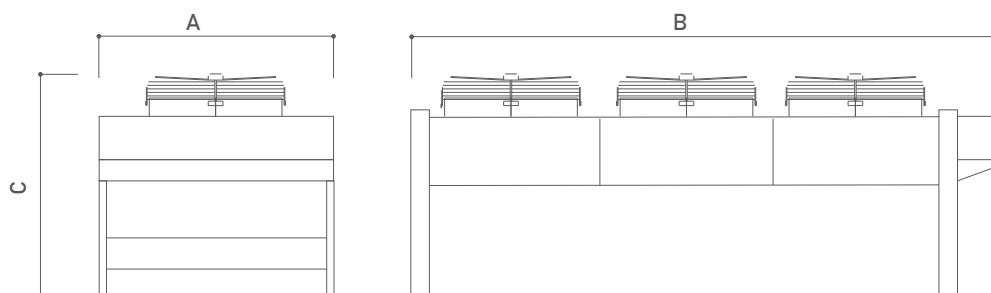

CDC MODELS:	030	035	040	045	050	060	070	080	090	105	120
Width A [mm]	2400	2400	2400	2400	2400	2400	2400	2400	2400	2400	2400
Depth B [mm]	3530	5030	5030	5780	5780	7530	8030	8930	9280	9240	9240
Height C [mm]	1565	1565	1565	1565	1565	1565	1565	1565	1565	2262	2262

Note:

For information on the weight and on the packaged product (dimensions and packaging type), please contact the company.

Operating Limits

- | Ambient temperature: **from -10 °C to +45 °C**
- | Outlet water temperature: **from -10 °C to +25 °C**



The values indicated are typical limits. Configurations for more demanding operating conditions are available upon request.

Main Applications



Insights Applications Sectors >> p.7

LASER

QBE TOTEM

**LIQUID CHILLERS FROM 12 TO 50 KW
WITH DOUBLE HYDRAULIC CIRCUIT
FOR COOLING LASER MACHINES**



QBE TOTEM Range Overview

The QBE TOTEM series is designed to guarantee precise and stable thermal control in laser applications. Equipped with a dual hydraulic circuit, it ensures simultaneous cooling of both the laser source and the optics, each with its own pump, dedicated temperature, and independent management. Thanks to the electronic hot-gas bypass valve

(precision ± 0.5 K) and the motorized 3-way valve (precision ± 1 K), QBE TOTEM maintains constant performance even under highly variable thermal loads.

The unit is compact, mounted on wheels, and designed for quick and safe maintenance. The integrated web server controller allows remote monitoring via Ethernet.

Main Components

- | **Stainless steel plate evaporator** (01): compact, high-efficiency
- | **Scroll compressor** (02): quiet, reliable, with anti-vibration mounts
- | **Aluminum microchannel condenser** (03): minimum refrigerant charge
- | **Fans** (04): 4-pole fan with sickle-shaped blades, protection grid, and automatic thermal reset. Option: EC fan with continuous speed control.
- | **Electronic hot-gas bypass valve** (05): ± 0.5 K precision for laser side
- | **Thermostatic expansion valve** (06): modulates refrigerant flow
- | **PVC atmospheric tank** (07): with sensors and drain valve
- | **Laser & optics pumps** (08) (09): each with bypass and pressure gauge
- | **Motorized 3-way valve** (10): ± 1 K tolerance for optics control
- | **Pre-heating resistance** (11): for temperature stability
- | **Controller with integrated web server**: monitoring and alarms
- | **IP44 electrical cabinet**: main switch, protections, numbered wiring

Laser Source Branch

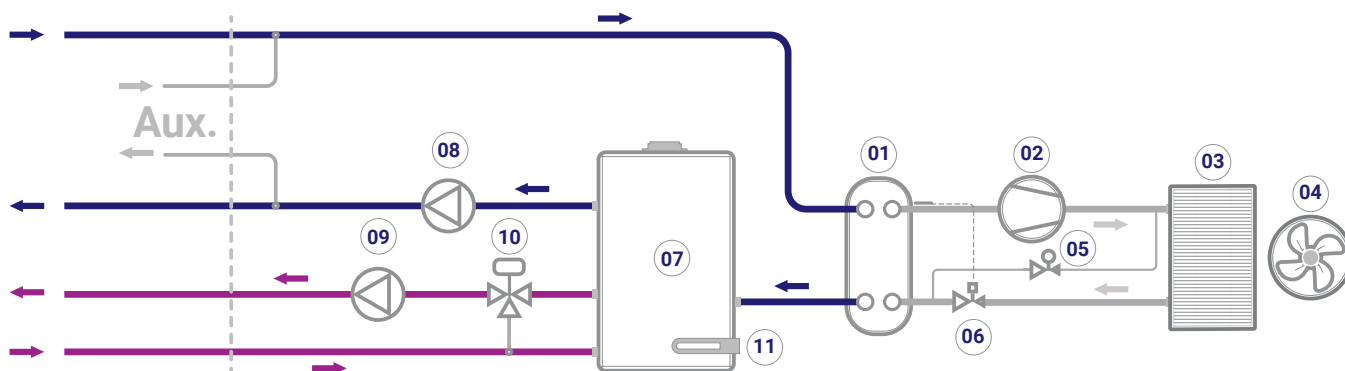

Optics Branch

Technical Data

QBE TOTEM MODELS		012	023	033	050
PERFORMANCES					
Air temperature	[°C]	32	32	32	32
Evaporator inlet water temperature	[°C]	26	26	26	26
Evaporator outlet water temperature	[°C]	21	21	21	21
Ethylene glycol	---	0%	0%	0%	0%
Cooling capacity	[kW]	12.58	23.26	36.65	52.22
Compressors power input	[kW]	3.16	6.06	8.47	13.51
Total power input	[kW]	5.56	9.46	13.09	18.57
Total absorbed current	[A]	11.39	16.75	22.50	32.52
Energy efficiency (pumps excluded)	EER	3.78	3.41	3.66	3.47
Water flow (laser source)	[l/h]	2164	4000	6304	8982
Available pressure (laser source) [1]	[kPa]	397	298	330	331
Water flow (optics)	[l/h]	600	600	600	600
Available pressure (optics) [1]	[kPa]	480	480	480	480
ELECTRICAL DATA					
Maximum power input (total)	[kW]	7.65	10.33	16.10	21.76
Maximum absorbed current (total)	[A]	13.78	21.47	26.95	37.13
Starting current	[A]	51.8	91.41	131.91	182.26
Fan power	[kW]	0.17	0.77	0.77	0.77
Fan current	[A]	1.80	1.70	1.70	1.70
Fans quantity	[#]	1	1	2	2
Pump power input (laser source)	[kW]	0.91	1.31	1.75	2.20
Pump absorbed current (laser source)	[A]	1.70	2.41	3.21	4.56
Pump power input (optics)	[kW]	1.33	1.33	1.33	1.33
Pump absorbed current (optics)	[A]	2.30	2.30	2.30	2.30
Power supply	[V/Ph/Hz]	400/3/50	400/3/50	400/3/50	400/3/50
IP protection degree	---	IP44	IP44	IP44	IP44
TECHNICAL DATA:					
Refrigerant	---	R407C	R407C	R410A	R410A
Compressor quantity	[#]	1	1	1	1
Refrigeration circuit quantity	[#]	1	1	1	1
Air flow	[m³/h]	3 700	7 300	14 000	12 500
Sound pressure level at 10 m in free field	[dBA]	48	50	51	52
Water connections size Source / Auxiliaries / Optics	[inch]	1 1/4"-3/4"-1/2"	1"1/4-3/4"-1/2"	1 1/2"-3/4"-1/2"	1 1/2"-3/4"-1/2"
Tank capacity	[dm³]	100	100	100	100

Note:

[1] Max head pressure at 26/21@32°C adjustable with the water bypass installed for standard both on the source and on optics sides.
Contact Friulair offices for more information

Available Options

QBE TOTEM MODELS	CODE
Thermal insulation on optics circuit	BK
Single pump 3 bar residual head pressure on optics	P3

Dimensions

QBE TOTEM MODELS	012	023	033	050
Width A [mm]	760	760	930	930
Depth B [mm]	780	780	1,570	1,570
Height C [mm]	1800	1800	1510	1510
Net weight [kg]	300	315	380	400

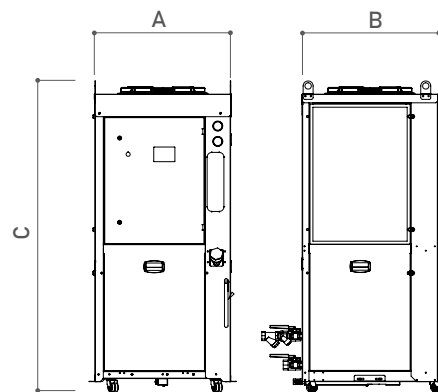

Note:

for information on the packaged product (dimensions, weights and packaging type), please contact the company.

FOCUS

Intelligent control

- Thermal precision: ± 0.5 K for laser, ± 1 K for optics
- Advanced diagnostics with 12 active alarms
- "Unit ready" mode with automatic operating condition confirmation

Advanced connectivity

- Ethernet with web interface
- Remote on/off control
- Remote alarm notifications

Compactness & maintenance

- Space-saving layout on wheels
- Easy access to all components
- Valves and bypasses for quick adjustments



QBE TOTEM Electronic Controller Display

Operating Limits



Refer to the most recent version of the technical manual for operating limits of the range.

Contact the company.

Main Applications



Insights Applications Sectors >> p.7

TGR

PLASTIC

R513A

**THERMOCHILLERS FROM 8 TO 21 KW
FOR INJECTION MOLDING
WITH R513A REFRIGERANT**



TGR Range Overview

The TGR thermochillers are the ideal solution for mold temperature control in injection molding. Equipped with an ecological R513A refrigerant circuit, the TGR models integrate Free Cooling functionality and are designed to deliver high energy efficiency and optimized cycle times.

Available in single-zone or dual-zone configurations, the TGR ensures high precision in temperature regulation thanks to the 3-way mixing valve with integrated

actuator and dedicated heating element. High-head pumps (P4 standard, P6 optional) guarantee effective circulation even in complex systems. The electronic control system and MODBUS RTU communication complete a versatile and easily integrable platform.

TGR has been developed in full compliance with European F-Gas Regulation and is suitable for indoor installation thanks to the exclusive use of non-ferrous materials and non-flammable refrigerant gas.

Main Components

- | High-efficiency hermetic scroll compressor
- | Brazed plate stainless steel evaporator
- | Compact, high-performance brazed plate condenser
- | High-head pump: P4 (std) or P6 (opt)
- | Insulated stainless steel pressurized buffer tank
- | 3-way valve with integrated actuator for precise temperature control
- | Microprocessor controller with RS485 MODBUS RTU communication
- | Galvanized, powder-coated steel frame on wheels
- | IP40-rated electrical cabinet

FOCUS

Smart Free Cooling

Automatic management of Free Cooling reduces consumption by exploiting outdoor temperatures.

Dual-zone configuration

Maximum flexibility for multi-mold processes, thanks to two independent circuits with autonomous temperature control.

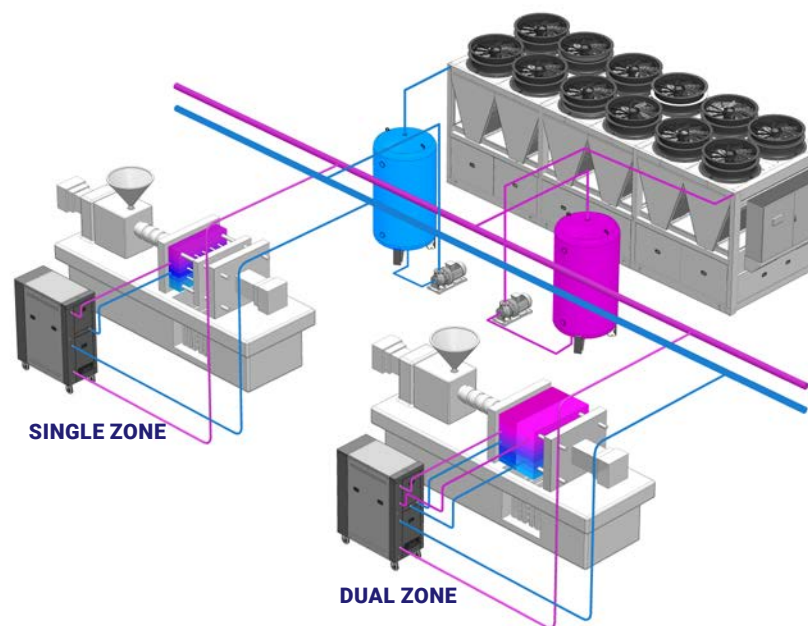

Technical Data

TGR MODELS		008	012	017	021
PERFORMANCES					
Cooling power [1]	[kW]	8.04	11.42	15.38	21.91
Compressors power input	[kW]	1.60	2.23	3.37	4.81
Total water flow [2]	[m3/h]	3.46	4.91	6.61	9.42
ELECTRICAL DATA					
Heating power [3]	[kW]	6	6	6	12
Primary pump power	[kW]	0.61	0.61	0.82	0.82
P4 pump power - Single zone version	[kW]	1.28	1.28	2.28	2.28
P6 pump power - Single zone version	[kW]	1.50	1.50	2.20	2.20
P4 pump power (each) - Dual zone version	[kW]	0.88	0.88	1.28	1.28
P6 pump power (each) - Dual zone version	[kW]	1.10	1.10	1.50	1.50
Power supply	[V/Ph/Hz]	400/3/50			
TECHNICAL DATA					
Refrigerant		R513A			
Compressor type		Scroll			
Evaporator type		Brazed plates			
Condenser type		Brazed plates			
Compressor quantity	[#]	1	1	1	1
Refrigeration circuit quantity	[#]	1	1	1	1
Water connections size [4]	[inch]	1"	1"	1" 1/2	1" 1/2
Tank capacity	[dm3]	15	15	15	15

Notes:

[1] Data referred to users water temperature 10 °C, delta T 2 °C, condenser water temperature 30/35 °C

[2] Data referred to the total water flow for single zone version. In each circuit of the dual zone version, the water flow rate is approx the half of the total

[3] Data referred to the heating power for each circuit

[4] Data referred to single zone version.

Available Options

TGR OPTIONS	CODE
Indirect Free Cooling	IFC
Dual zone temperatures	2Z
P6 pump	P6
Visual & sounding alarm	VSH
Non ferrous heating resistor	RH
Regulable water bypass [1]	BR
Alternative Gateways [2]	AG

Note:

[1] also available for dual zone (2Z) version

[2] AG option consists on a gateway configuration enabling selection between Profibus, Profinet or BACnet communication. The setting is responsibility of the user.



Complementary unit available: CDC dry cooler >> [p.42](#)

Dimensions

TGR MODELS	008	012	017	021
NET DIMENSIONS				
Width A [mm]	500	500	500	500
Depth B [mm]	1 100	1 100	1 100	1 100
Height C [mm]	1 350	1 350	1 350	1 350

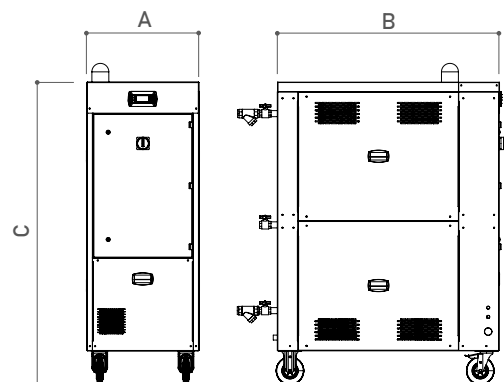

Note:

For information on the weight and on the packaged product (dimensions and packaging type), please contact the company.

Operating Limits

- Pure water from **5 °C to 90 °C**
- Outlet water temperature precision: **±0.2 K°**

Main Application:



Insights Applications Sectors >> [p.7](#)

BEYOND CHILLERS



SYSTEM COMPLETION SOLUTIONS

For optimal chiller integration into the system, Friulair offers a selection of auxiliary components to ensure efficient and safe distribution of the heat transfer fluid:

Pump groups

Compact or modular solutions for fluid circulation, available with single or twin pumps, valves, and control systems.

Sizing and selection available on request.



Plate heat exchangers (inspectable type)

Ideal for separating hydraulic circuits and protecting the evaporator in complex applications.

Easy to maintain and clean.

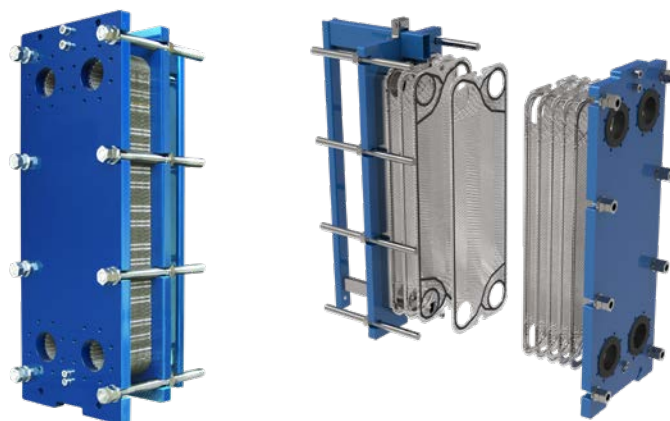

SERVICE & SUPPORT

Concrete Support, Wherever You Need It

Friulair exports more than 67% of its production, currently reaching over 70 countries worldwide. Our distribution and service network is constantly expanding, with the goal of offering ever closer customer support, also at an international level.

Technical And Commercial Support

Our team assists customers in selecting the most suitable product and in managing both pre- and post-sales phases. Support is delivered in collaboration with our local distributors, ensuring responsiveness and efficiency.

Technical Assistance And Maintenance

Friulair supplies original spare parts, start-up contracts, scheduled maintenance programs, and technical training for installers and technicians. We are committed to continuously improving our services, to provide increasingly targeted and qualified interventions.



COMPRESSED AIR SOLUTIONS

In addition to our complete range of industrial chillers, Friulair also offers a dedicated line for compressed air treatment.

The Dryers Division Includes:

- Refrigeration dryers, compact and efficient, for moisture removal in industrial applications.
- Adsorption dryers, for critical conditions and applications requiring ultra-dry, high-purity air.
- Filters and condensate separators, ensuring clean and safe compressed air.
- Integrated condensate management solutions, with drain devices and oil separators.

With this comprehensive offering, Friulair provides reliable, efficient, and tailored compressed air treatment systems for every need.





ITALIAN EXCELLENCE AND QUALITY WORLDWIDE

We put the customer at the heart of every project, delivering reliable, efficient, and sustainable solutions for compressed air treatment and industrial process cooling. We promote Italian ingenuity and quality worldwide. Our focus is on continuous innovation, environmental sustainability, quality, and transparency.

Friulair S.r.l.
Via Cisis 36
33052 Cervignano del Friuli (UD) – Italy

Email:
friulair@friulair.com

Phone:
(+39) 0431 939416

Website:
www.friulair.com

